



3-IN-1 PLOW

Operator's Manual



844.BLU.PLOW
(844.258.7569)

www.danielsplows.com

Congratulations!

By purchasing the Daniels 3in1 Plow, you can now benefit by owning the latest in the state-of-the-art snow plowing equipment.

Before you begin . . .



IMPORTANT! – It is important to completely read and understand this owner’s manual for your Daniels 3in1 Plow prior to installation and use. Failure to do so may adversely affect the performance of your plow.

Prior to completing the installation process, make sure your loader meets all the requirements needed to operate the Daniels 3in1 Plow. Your loader must also be equipped with an auxiliary hydraulic circuit (i.e., 3rd valve). NOTE: If your loader is not equipped with an auxiliary circuit, you will need to add a valve and plumb it into the loader’s hydraulic system. Contact your loader equipment dealer for assistance.

Caution: Prior to starting the installation process, make sure appropriate safety equipment is available at the work site. Provide a fire extinguisher and have it immediately available if welding. Safety glasses, gloves, hearing protection, and protective clothing should be worn whenever welding, using grinders or cutoff saws.

Recommended Wheel Loader Size

All 3in1 Sizes: 15,000 to 45,000 lbs



PLOW INSTALLATION

Use the parts and diagram drawings to aid in the installation process (pages 8-13).

- 1. Connect the Daniels 3in1 Plow to the loader, making sure the plow is securely locked in place**



IMPORTANT!

Check to be sure the 8" X 8" square tube (Throat Weldment) is parallel to the pavement, as shown (Page 13, Diagram 2). When the boom configuration is set to allow the throat weldment to be parallel to the pavement, create a visual reference point that is visible from the loader cab by marking or painting a straight line between the loader frame and the boom as shown (Page 13, Diagram 5). This will allow the operator to always return the boom to the correct plowing position with the throat weldment parallel to the pavement during use.

2. Hydraulic hose installation

Route the two hydraulic hoses from the hydraulic ports on the loader to the two empty ports on the hydraulic manifold. The fittings to connect to on the front of the manifold are -12 SEA O RING Boss fittings. Utilize the hydraulic hose mount riser (Part #4) when routing the hoses. Make sure the hoses will not be pinched when the plow is raised, lowered, or hydro turned. Secure the two hoses together with nylon zip ties as needed (Page 13, Diagram 1). To confirm you have hoses of the appropriate length, raise the plow and roll the boom forward as if dumping a bucket. Measure your hose length from this position to ensure the hoses are not pulled or stretched during operation.



IMPORTANT!

For the easiest and safest shipping of the Daniels 3in1 Plow the wings may be bolted open. Check for and remove this bolt prior to applying any hydraulic pressure to the plow. The bolt is located on the back side of the plow under both wing cylinders. The bolt connects the outer most rib of the center board section of the 3in1 Plow to the inner most rib of the wing section of the 3in1 Plow.



PLOW INSTALLATION

Use the parts and diagram drawings to aid in the installation process (pages 8-13).

3. Electric switch installation

Under the manifold cover, the plow end of the wire harness has been pre assembled prior to shipping. Prior to installing the electric wire harness and switch turn off the machine and remove the key.

Connect the longer machine end of the wire harness to the pre assembled plow end of the wire harness by connecting the electrical connector plug to the matching plug connected through the wall of the manifold cover (Part #46).

Route the machine harness wire from the plug on the manifold cover up the boom arms of the machine to the cab. Make sure the wire will not be pinched when the plow is raised, lowered, or hydro turned. Secure the wire with nylon zip ties as needed (Page 13, Diagram 1). To confirm you have allowed the appropriate length of wire, raise the plow and roll the boom forward as if dumping a bucket. Confirm your wire length from this position to ensure the wire is not pulled or stretched during operation.

Use existing clamps along the boom arm or nylon zip ties to secure the wire to the boom. Pay particular attention to the transition point from the machine body to the hinges of the boom arms. In this area be sure the wire harness is clear of any pinch points that may be present when the boom is lifted and lowered. Also, be sure to allow enough slack that the wire harness is not broken or stretched after being secured because of the machine articulation or movement between the machine body and the boom arms. After the machine harness is properly secured to the boom of the machine, disconnect the electrical plug to the pre assembled plow harness at the manifold cover prior to continuing the electrical installation process. Cover both connectors with the provided caps to prevent contamination from entering the electrical system.

Determine a suitable location on the machine firewall to pass the boom wire from the outside of the cab to

the interior of the machine cab. This may pass through a boot along the steering column, or through a hole covered from the factory with a plug. If a hole must be drilled, select an area with no obstruction, on either side, and drill a 1/8" pilot hole to verify exact location before drilling a larger hole with a hole saw. Provide a boot or grommet to protect the harness from sharp edges.

Install the black switch box in the cab. Install in a convenient location for the operator. It is recommended that the switch box be mounted in a location which limits the amount of arm movement for the operator between the switch and the 3rd valve control of the machine. Use heavy duty two sided tape or a mounting strap to mount the switch in the desired location.

Route the remaining wire from the machine harness within the cab from where it passes through the firewall to the installed switch. Keep the wire within the cab routed behind the dash, wall, and door panels where possible. Loose, exposed wire that is not properly secured can be damaged or become tangled with the operators feet and the pedals.

The shorter lead from the switch box should be routed in the same fashion as the manifold lead within the cab to the vehicle fuse panel. At the fuse panel the black power wire connects to a 12 volt fuse. Secure the **white** ground wire to a ground post or mounting screw near the fuse panel.

With the machine off and the key removed, connect the aluminum switch connectors of the machine side of the wire harness to the plow side of the wire harness. It is recommended that the covers for the electrical connectors are placed in a tool box or compartment on the machine or within the cab for safe keeping while the plow is installed on the machine. This will also allow for easy access by the operator when the plow is removed in order to cover the ends to keep them free of contamination.



PLOW INSTALLATION

Use the parts and diagram drawings to aid in the installation process (pages 8-13).

4. Plow function cycle check

Set the parking brake and start the machine. Raise the plow a few inches off the ground by using the boom lift control in the cab, keeping the throat weldment level with the ground.

With the electrical switch in the middle “neutral” position, slowly cycle the plow fully to the left and right until the plow moves smoothly in both directions. Visually check for hydraulic leaks.

Return the plow to the straight position.

Next, move the electrical switch to either the left or right position. Using the 3rd valve control in the cab cycle the wing rotation fully out and then back. Repeat until the wing moves smoothly in both directions. Move the electrical switch past neutral to the opposite wing position. Using the 3rd valve control in the cab cycle the opposite wing fully out and then back in. Repeat until the wing moves smoothly in both directions.

After or during the plow function cycle check 3 to 5 gallons of hydraulic oil may need to be added to the system. The quantity of oil needed to be added will depend on the capacity of the hydraulic system. Consult the machine’s owners manual for proper procedures in checking the oil level, the type of oil to be used, and filling.

After the machine and plow have the proper oil levels, take some time to continue testing the system and familiarizing yourself with the functions of the plow. Pay attention to the spacing and clearance needed as you angle the plow in many different positions including the box position and straight position.



WARNING!

During ALL operations of the plow during installation or plow use it is the operators responsibility to make sure the entire area around the machine and plow are clear of obstacles and people. Failure to do so can result in damage, injury, or death.



WARNING!

Never use hands to search for fluid leaks as high pressure fluid can have sufficient energy to penetrate the skin. Hydraulic fluid entry into skin can cause blood poisoning and must be treated by professional medical personnel immediately.



WARNING!

Throughout the entire plow function cycle check visually check for hydraulic leaks.



TRANSPORTING TO WORKSITE

To raise the plow, move the bucket lever to the “roll back” position. This will cause the chains to tighten and the plow to rise.

Always transport the Daniels 3in1 Plow with the wings folded forward. With the wings folded forward, raise the plow and hydro turn the plow fully to the right, away from oncoming traffic, to minimize the width of the plow (Page 13, Diagram 6).

Always use the hazard and running lights and stay as far to the right lane and road shoulder as possible. Transport at a safe speed with the plow held at a low profile to the road. Check your local city, county, and state rules and regulations of the road for proper and legal transportation. The use of warning signs and a pilot vehicle may be required.

After arriving at the plowing location, return the plow to the straight position with the wing hinges perpendicular to the ground and the throat weldment in the proper plowing position prior to use.



WARNING!

Whenever folding the wings or angling the blade make sure obstacles and people are clear of the rotation area prior to applying hydraulic flow to the cylinders.

OPERATION

IMPORTANT: It is recommended to use the roll back lever to raise or lower the plow. The boom lift should only be used to raise the plow when stacking snow. Use the bucket roll back lever for raising or lowering the plow during normal operation. Position the loader boom so the throat weldment is parallel to the pavement using the reference mark created during the install process (Page 13, Diagram 2). Before plowing, roll back on the backing plate until the chains tighten, then roll the backing plate forward allowing approximately 2” of slack in the chains (Page 13, Diagram 3). Be sure the boom is set at the proper plowing position (Page 13, Diagram 5).



OPERATION

IMPORTANT: If the plow is hydro turned and the throat weldment is not parallel to the ground, one end of the plow will lift up off the pavement and the other end will dig into the pavement. This will result in damage to the pavement, poor plowing performance and uneven wear on the cutting edge (Page 13, Diagram 4). The same result will occur when plowing in the proper position if the plow is rolled back in the hydro turned position. The plow should only be raised when the blade is in the straight position. The standard swivel plate which is located at the back of the throat weldment where it is mounted to the backing plate will help diminish these effects, however, the rotation of the swivel plate SHOULD NOT be relied upon to eliminate these effects. The amount of swivel, the contour of the ground, and the boom height will all affect the amount of dig and lift that occurs at the ends of the plow when not plowing with the throat weldment parallel to the ground or when lifting the plow while in an angled position.

Lower the plow in a slow and smooth motion. Dropping the plow may cause the cutting edge bolts to loosen and cause damage to the plowing surface.



CAUTION!

**Know the areas you are plowing!
Hitting manhole covers or other hidden
objects can cause property or equipment
damage as well as injury to the operator.**

MAINTENANCE

Before each use of the Daniels 3in1 Plow, check to make sure the cutting edge bolts and all hardware are securely tightened and that all hydraulic lines are secured and in good condition. Tighten or replace hardware as needed. Check weldments for signs of fatigue and repair as necessary. Examine all surfaces for excessive wear. Apply grease to all zerk fittings periodically throughout the year. Make a visual check for fluid leaks. It is also suggested that all cutting edge bolts be checked and tightened as needed throughout the plowing season.



WARNING!

Never use hands to search for fluid leaks as high pressure fluid can have sufficient energy to penetrate the skin. Hydraulic fluid entry into skin can cause blood poisoning and must be treated by professional medical personnel immediately.

3-IN-1 PLOW

Operator's Manual

BluePlow®

MAINTENANCE

If you feel the hydraulic pressure settings of the manifold are not set properly or you feel the performance is being hindered by their setting DO NOT attempt to adjust the settings. Doing so may cause performance problems and void the warranty. If you feel adjustments need to be made, contact your dealer for assistance.

The center wear edge, wing wear edges, and all wear items should be checked regularly and replaced before completely worn away to prevent damage to the main plow mold board or wings.

REMOVING THE PLOW

To remove the plow from the loader, set the parking brake and turn off the loader. Relieve all hydraulic pressure by cycling the valves. Disconnect the hydraulic lines from the loader. Disconnect the electrical wire harness from the manifold. Secure the wire harness on the loader to prevent the possibility of damage to it when not connected to the plow. Connect the hydraulic hose couplers together to keep contaminants out of the hydraulic system. Place the electrical caps on each end of the exposed terminals to keep contaminants out of the electrical system. Disconnect the loader from the backing plate.

OFF SEASON STORAGE AND MAINTENANCE

It is recommended the Daniels 3in1 Plow be stored indoors. Connect the hydraulic couplers together and place the caps on each end of the electrical wire harness to prevent system contamination. Grease all zerks before storage, paying particular attention to the wing hinges. Apply a lubricant such as grease on the exposed cylinder rods to inhibit corrosion.



ITEM NO.	PART NO.	DESCRIPTION	18 FT./QTY.	20 FT./QTY.	22 FT./QTY.
1	DP-1004	12' MOLD BOARD FOR 3in1 PLOW	1	1	1
2	31523	PUSHER ROD ASSEMBLY	2	2	2
3	16154	CYLINDER 3.0	2	2	2
4	DP-1012	12' TURN TABLE	1	1	1
5	31521	ROTATION KNUCKLE (RIGHT)	1	1	1
6	31520	ROTATION KNUCKLE (LEFT)	1	1	1
7	DP-060	HINGE PIN	2	2	2
8	DP-061	HINGE PIN RING	2	2	2
9	31401	4' FORWARD PUSHWING - LEFT	-	1	-
10	31522	ROTATION KNUCKLE AND ARM PIN	8	8	8
11	DP-1014	THROAT WELDMENT	1	1	1
12	14745	KING PIN 2-1/2" FOR 3400 & 4200 MODELS	1	1	1
13	DP-1017	BACKING PLATE - BLANK	1	1	1
14	31402	4' FORWARD PUSHWING - RIGHT	-	1	-
15	DP-1018	MANIFOLD SUPPORT	1	1	1
16	14737	MOLD BOARD TRIP PIN	7	7	7
17	18215	1/2-13 x 2 1/4" LONG HEX HEAD BOLT, GRADE 5 ZINC PL	7	7	7
18	18757	FLAT WASHER 1 1/2 SAE	7	7	7
19	18425	LOCK NUT, NYLON 1/2"-13	24	24	24
20	14465	SKID SHOE ASSEMBLY	2	2	2
21	18810	3/8" SPLIT LOCK WASHER ZINC PLATED	6	6	6
22	18160	HEX HEAD BOLT 3/8"-16 X 1"	6	6	6
23					
24	14747	CYLINDER PIN FOR 31, 3400 & 4200 MODELS	4	4	4
25	18200	HEX HEAD BOLT, 1/2-13 X 3"	14	14	14
26	14751	BACKING PLATE PIN	2	2	2
27	18205	BOLT, HEX HEAD 1/2"-13 x 3-1/2", GRADE 8, ZINC PLATED	3	3	3
28	18815	SPLIT LOCK WASHER, 1/2"	4	4	4
29	18190	HEX HEAD BOLT, 1/2"-13 X 2"	4	4	4
30	18153	5/16"-18 X 1-3/4" HEX HEAD BOLT ZINC PLATED	5	5	5
31	18805	SPLIT LOCK WASHER, 5/16"	13	13	13
32	18759	FLAT WASHER, 2-1/2" USS STANDARD ZINC PLATED	1	1	1
33	18540	CLEVIS PIN 3/4 X 3	5	7	8
34	18740	FLAT WASHER, 3/4" SAE	5	7	8
35	18565	COTTER PIN 1/8" X 1-1/2", ZINC	5	7	8
36	14680	TRIP SPRING 21.25"	8	10	12
37	18265	HEX HEAD BOLT 1"-8 x 3", GRADE 8, ZINC PLATED	8	10	12
38	18825	SPLIT LOCK WASHER FOR 1" SCREW YELLOW ZINC PLATED	8	10	12
39	16147	CYLINDER 4.0	2	2	2
40	14126	4' WING CUTTING EDGE FOR 3120 MODEL	-	2	-
41	14063	CENTER BOARD CUTTING EDGE FOR 3100 MODEL	2	2	2
42	14506	CHAIN HOLDING PLATE	4	4	4
43	78139	SWIVEL LOCK PIN	1	1	1
44	18547	LOCKING PIN WITH WIRE RETAINER 1/4" DIA.	1	1	1
45	31524	CYLINDER PIVOT PIN	2	2	2
46	14128	3' WING CUTTING EDGE FOR 3118 MODEL	2	-	-
47	18125	3/4"-10x3-1/2" CARRIAGE BOLT GRADE 8	24	28	32
48	18445	3/4"-10 NYLON INSERT LOCKNUT, GRADE 8 YELLOW ZINC PLATE	26	30	34
49	18120	3/4"-10x2-1/2" CARRIAGE BOLT GRADE 8	2	2	2
50	16701-2	PLASTIC HOSE CLAMP BRACKET	10	10	10
51	16701-3	CLAMP PLATE	5	5	5
52	18531	TRANSPORT CHAIN, 1/2 x 30	2	2	2
53	HOSE 1 LEFT	HOSE 1 - LEFT	4	4	4
54	HOSE 1 RIGHT	HOSE 1 - RIGHT	4	4	4
55	18410	LOCKNUT, NYLON 5/16"-18	4	4	4
56	16833	JUNCTION MANIFOLD	1	1	1
57	18155	5/16"-18 X 2-1/2" HEX HEAD CAP SCREW, GRADE 8	6	6	6
58	31301	3' FORWARD PUSHWING - LEFT	1	-	-
59	31302	3' FORWARD PUSHWING - RIGHT	1	-	-
60	31501	5' FORWARD PUSHWING - LEFT	-	-	1
61	31502	5' FORWARD PUSHWING - RIGHT	-	-	1
62	14127	5' WING CUTTING EDGE FOR 3122 MODEL	-	-	2
63	14129	WEAR BAR EDGE FOR 3118 MODEL	2	-	-
64	14139	WEAR BAR EDGE FOR 3120 MODEL	-	2	-
65	14149	WEAR BAR EDGE FOR 3122 MODEL	-	-	2
66	16831	3-IN-1 HYDRAULIC MANIFOLD	1	1	1
67	16832	MANIFOLD COVER	1	1	1
68	18154	5/16"-18x3/4" HEX HEAD CAP SCREW, GRADE 8, ZINC PLATE	6	6	6
69	14064	4' CENTER OVERLAP CUTTING EDGE FOR 3100 MODEL	1	1	1
70	14507	CURB GUARD FOR 34, 4200 & 2700	4	4	4
71	18225	HEX HEAD BOLT, 5/8"-11 x 2"	8	8	8
72	18435	LOCK NUT, NYLON 5/8"-11	8	8	8
73	18111	GREASE FITTING, 1/4"-28 x 17/32" UNF MALE	17	17	17



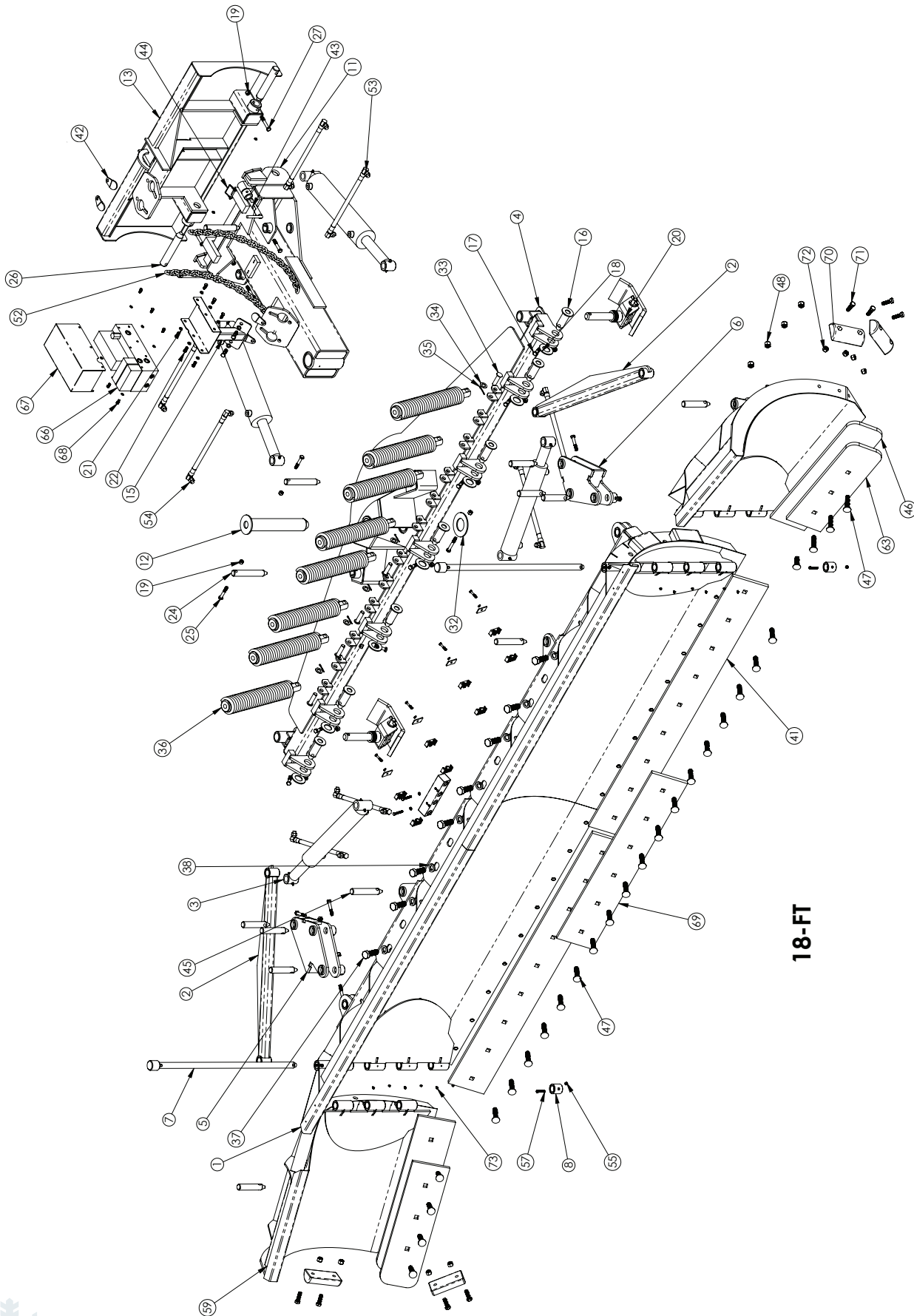

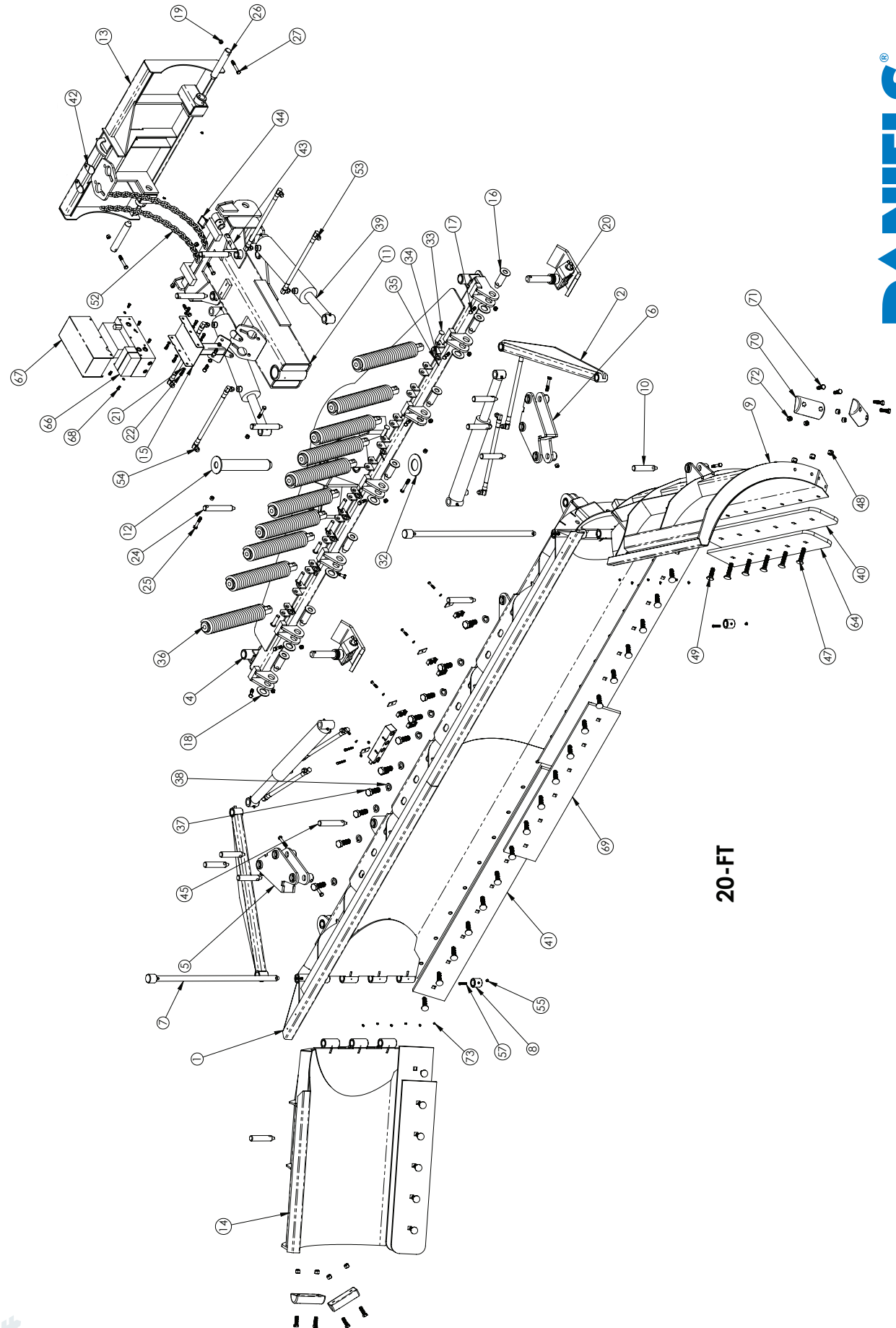

20-FT



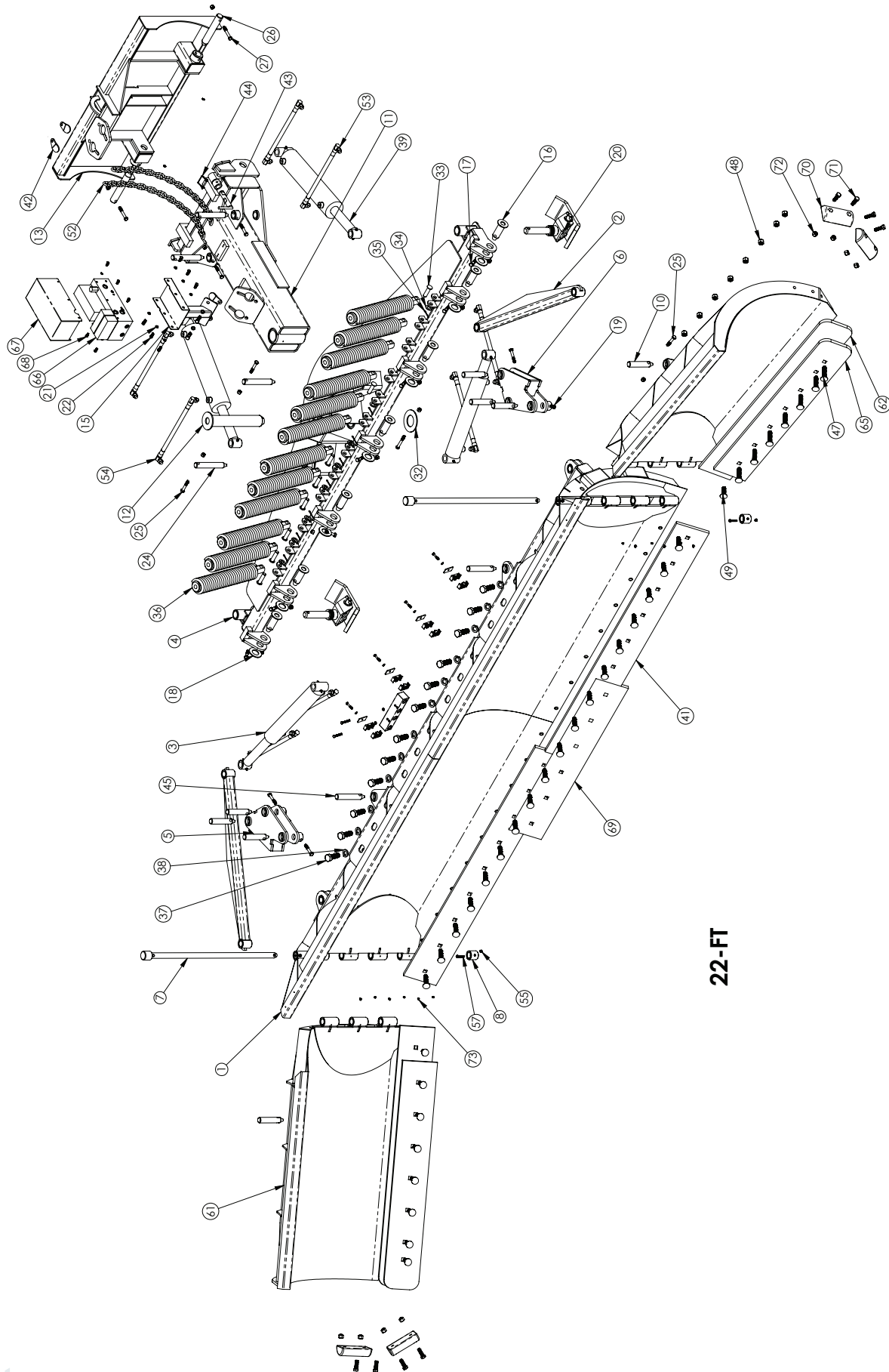

22-FT



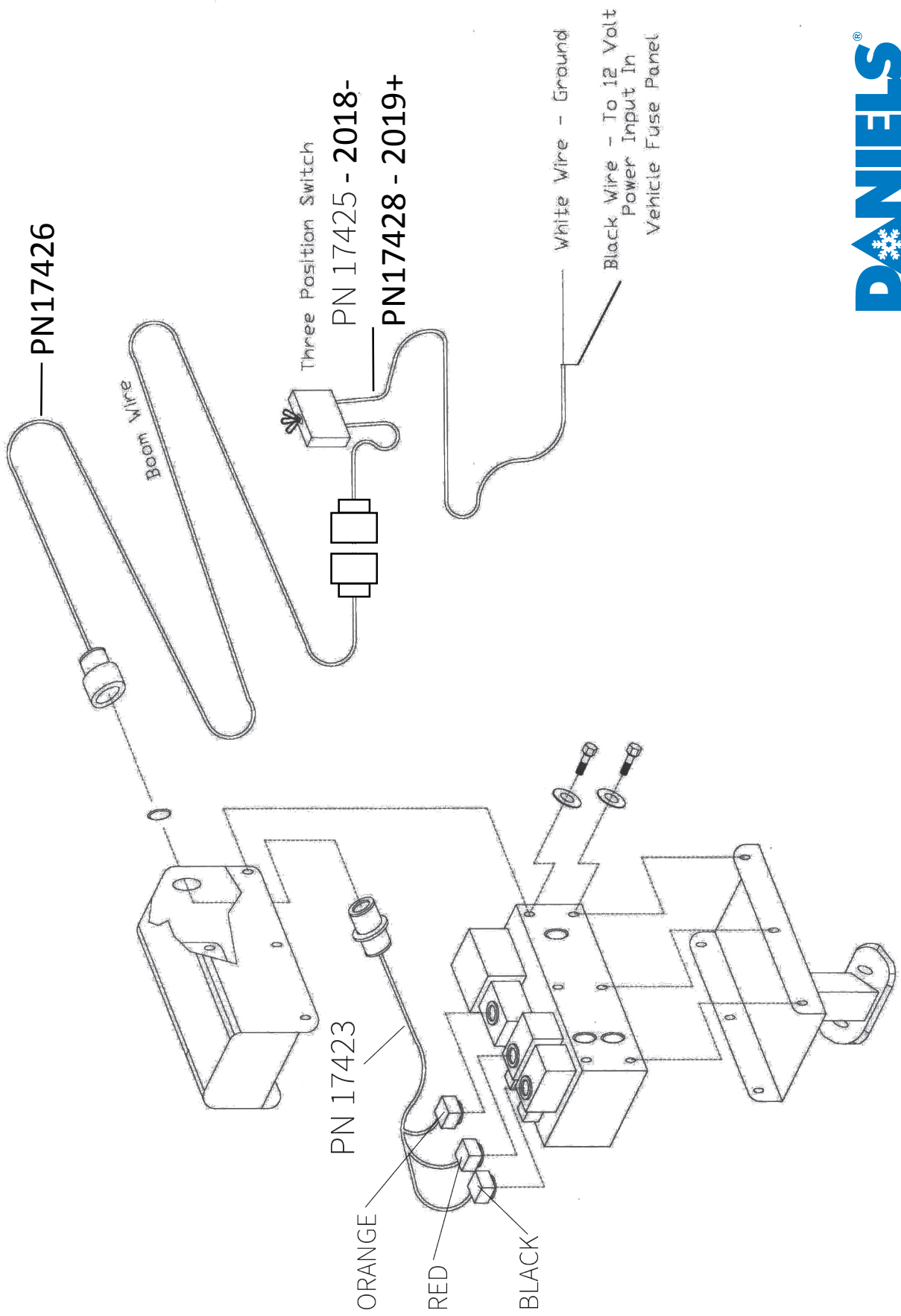

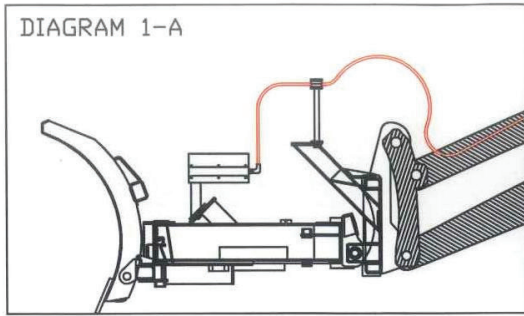

DIAGRAM 1-A

 **CORRECT**
HOSE INSTALLATION

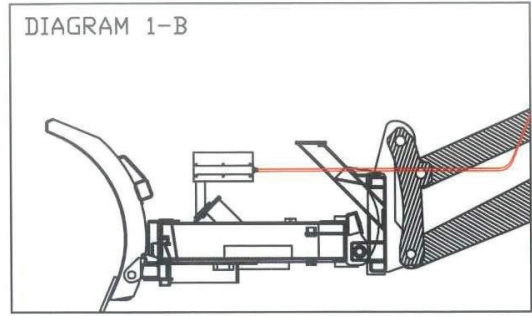

DIAGRAM 1-B

 **INCORRECT**
HOSE INSTALLATION

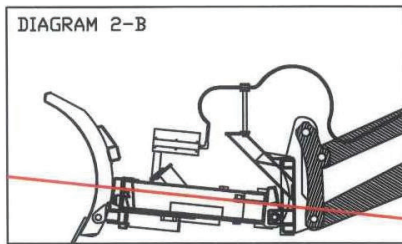

DIAGRAM 2-B

SQUARE TUBE NOT PARALLEL WITH PAVEMENT
 **INCORRECT** OPERATING POSITION

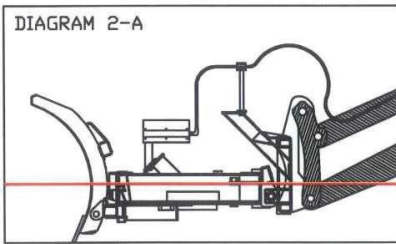

DIAGRAM 2-A

SQUARE TUBE PARALLEL WITH PAVEMENT
 **CORRECT** OPERATING POSITION

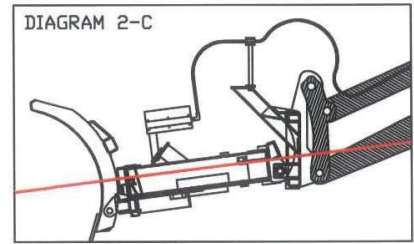

DIAGRAM 2-C

SQUARE TUBE NOT PARALLEL WITH PAVEMENT
 **INCORRECT** OPERATING POSITION

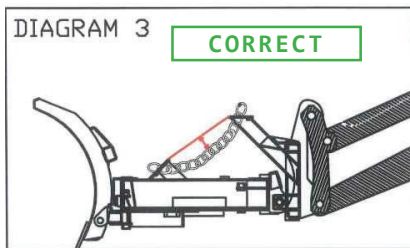

DIAGRAM 3

CORRECT

SQUARE TUBE PARALLEL WITH PAVEMENT
2 INCHES OF SLACK IN CHAIN
CORRECT OPERATING POSITION

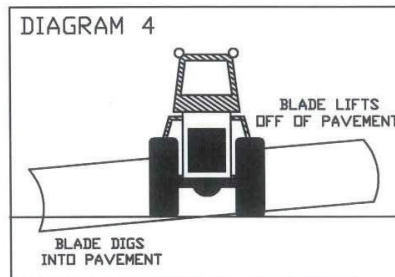

DIAGRAM 4

BLADE DIGS INTO PAVEMENT

BLADE LIFTS OFF OF PAVEMENT

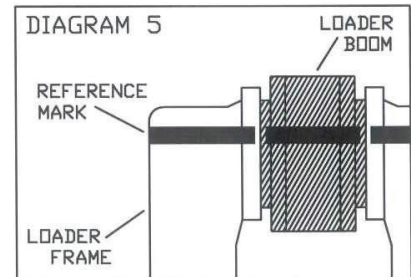

DIAGRAM 5

REFERENCE MARK

LOADER FRAME

LOADER BOOM

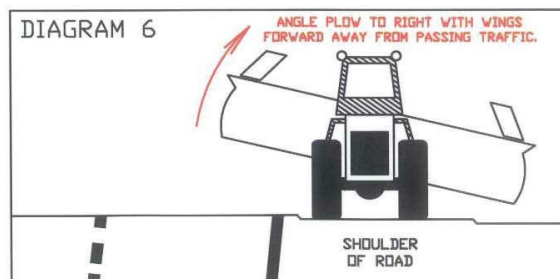

DIAGRAM 6

ANGLE PLOW TO RIGHT WITH WINGS FORWARD AWAY FROM PASSING TRAFFIC.

SHOULDER OF ROAD

STAY AS FAR TO RIGHT OF ROAD AS POSSIBLE.



Daniels Plows, Inc. Warranty Information

Daniels Plows warrants to the original purchaser of a Daniels snowplow that the snowplow sold by Daniels will be free of defects in workmanship and material for 24 months from the date of delivery.

In the event any Daniels snowplow fails to comply with this warranty during the warranty period, and purchaser notifies Daniels in writing of the defect and provides proof of the original purchase date, Daniels, at its sole and absolute discretion shall authorize its designated representative to repair or replace the defective part(s), or shall correct such nonconformity by shipment of parts from the factory in repair or replacement of defective part(s) provided that the snowplow has been stored, installed, operated and maintained in accordance with Daniels' instructions, has not been subject to abuse or misuse, including but not limited to any modification to or installation of the snowplow by anyone other than Daniels or an authorized Daniels representative, has not been subject to any repair work or replacement parts not authorized in writing by Daniels, and has not been used in any way other than its intended purpose. This warranty does not apply to any "wear parts" such as cutting edges, springs, wear shoes and curb guards.

The purchaser's remedy in respect to any defect in the snowplow or any loss of damage arising directly or indirectly from any defect, nonconformity or defective workmanship in the snowplow is limited to providing the repair or replacement of parts thereof. The snowplow or the applicable part thereof must be returned to Daniels by purchase F.O.B. unless, in Daniels' sole discretion, Daniels authorizes its designated representative to repair or replace the part at the designated representative's site. The snowplow or the applicable part thereof will be returned to purchaser by Daniels F.O.B. In any event, labor charges shall not be included in this warranty and shall be due and payable by purchaser immediately upon receipt of invoice. Field replaceable spare parts supplied by Daniels are warranted for the later of the unexpired portion of the snowplow warranty or 30 days.

The foregoing warranties set forth are exclusive and no other warranty is expressed or implied. Daniels specifically disclaims all other warranties whether statutory, express or implied, including all warranties of merchantability and fitness for particular purpose and all warranties arising from course of dealing or usage of trade, including but not limited to the acts or omissions of dealers, distributors, agents, contractors, suppliers and any tier or other designated representatives of Daniels.

Attachment of a snowplow to motor vehicles is at the risk and expense of the purchaser. Compliance with applicable motor vehicle regulations is the responsibility of the installer. Daniels does not assume any liability for any damage to a motor vehicle resulting from the attachment or from the use of a snowplow. Daniels does not assume any liability for the cost of modification of the snowplow or the vehicle required to attach the snowplow.

Daniels, and any of its agents, contractors, suppliers and any tier shall not be liable in contract, in tort (including negligence and strict liability), or otherwise for damage or loss of property, loss of profits or revenue, loss of use of equipment or cost of capital, claims of purchaser or any and all of its' customers, vendees, etc., or for any special, indirect, incidental, or consequential damages whatsoever.

The attached warranty registration form must be completed and returned to Daniels by purchaser to activate this warranty.



Daniels Plows
PO BOX 431 Hebron, IL 60034 USA
844-BLU-PLOW • www.danielsplows.com



Daniels Plows, Inc. Warranty Information

In order to qualify for the 24 month warranty, this form must be completed and returned to Daniels Plows, Inc. within 30 days of original purchase.

OR

please go to www.danielsplows.com/warranty to register.

Date Purchased:

Dealer Name / Address:

Model:

Serial Number:

Company Name: **Owner:**

Address: **City:** **State:**

Zip: **Phone:** **Mobile:**

FAX: **Email:**

Was this snowplow assembled and installed by the dealer? YES / NO

Was safe operation of this snowplow reviewed by the dealer? YES / NO

Was the owner's manual included with the snowplow? YES / NO

Please mail completed form to:

Daniels Plows

PO BOX 431 Hebron, IL 60034 USA



844-BLU-PLOW • www.danielsplows.com

